

# VORTEX® COOLED PACKING CASES

## State-of-the-art cooling technology

*The advanced design of VORTEX cooled packing cases significantly improves heat transfer, resulting in extended sealing component life. VORTEX cases also simplify maintenance and eliminate gas-to-coolant leakage.*

### SUPERIOR HEAT TRANSFER

VORTEX packing cases feature single-piece cups with tangential coolant channels. The tangential configuration of the coolant channels creates turbulent flow and higher coolant velocity, virtually eliminating “dead space.” The entire volume of coolant passes through a single, continuous cooling channel from inlet to outlet, resulting in superior heat transfer.

The VORTEX cooled packing case complies with API 618, unlike the “plate and channel” design currently used in moderate to high-pressure applications.

### REDUCED LEAKAGE

The VORTEX cooling design may also be used instead of conventional pressed-fit coolant cups, which have the potential for gas-to-coolant leakage at higher pressures. The single-piece construction of the VORTEX cooling cup eliminates pressed-fit cup leakage. The design also has no rod-encircling O-rings to hamper maintenance.

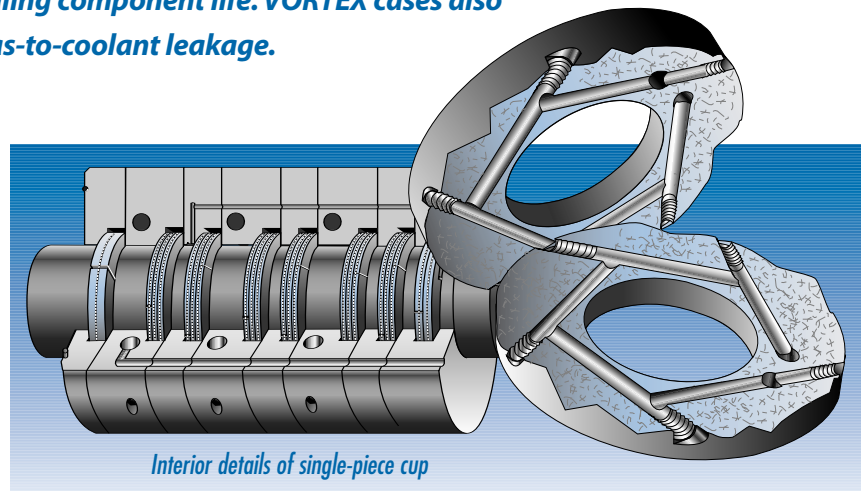

### IMPROVED CLEAN-OUT

The straight-sided tangential cooling channels in VORTEX cooled cases offer superior accessibility through exterior cleaning ports for easy removal of blockage. Even the hardest deposits can be removed quickly with a hand drill.

### ENGINEERED FOR EFFICIENCY

VORTEX packing cases provide more efficient cooling than conventional designs. Consult your Cook Compression representative today for more information or a quotation specifically engineered for your application.

### BENEFITS

- ▶ COOLER OPERATION EXTENDS SEALING COMPONENT LIFE
- ▶ MOST EFFICIENT HEAT TRANSFER
- ▶ ELIMINATES GAS-TO-COOLANT LEAKAGE
- ▶ COMPLIES WITH API 618
- ▶ SIMPLIFIES INSTALLATION AND MAINTENANCE
- ▶ EASY ACCESS FOR CLEAN-OUT