

STATIC-PAC® SHUTDOWN SEAL

Contains high-pressure gas during compressor shutdown

A Static-Pac seal prevents the escape of high-pressure gas from the packing case assembly during and after compressor shutdown. In addition to containing valuable gases, Static-Pac seals improve safety and enhance environmental compliance.



HOW A STATIC-PAC SEAL WORKS

Static-Pac can be retrofitted to most gas compressor packing case assemblies and easily adapts to a wide range of compressor operating conditions. The assembly replaces one to two cups in the low-pressure side of the rod packing case.

Conventional rod rings unload during shutdown, permitting high-pressure gases to escape. However, a Static-Pac assembly activates upon shutdown,

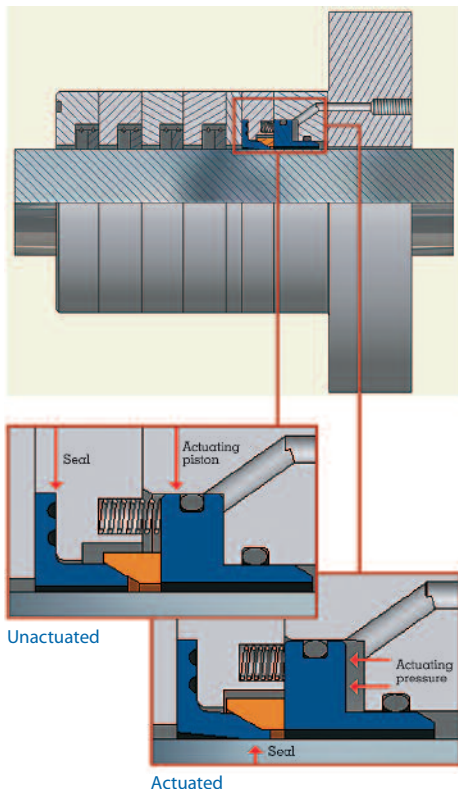

Virtually eliminates fugitive emissions of expensive, noxious and explosive gases.

mechanically wedging a lip seal tightly against the piston rod. The flexible polymer seal conforms to the rod circumference, locking in high-pressure gas.

Any combination of manual or automatic interlocks may be used to activate the seal. When activating pressure is released during compressor start-up, the Static-Pac seal lifts off the rod surface to allow free movement of the rod.

FAST PAYBACK

By virtually eliminating the release of valuable compressed gases, Static-Pac seals pay for themselves many times over. In most circumstances, the payback

BENEFITS

- ▶ RAPID PAYBACK WITH LONG-TERM SAVINGS
- ▶ CONTAINS VALUABLE GASES
- ▶ IMPROVES SAFETY
- ▶ ENHANCES ENVIRONMENTAL COMPLIANCE
- ▶ REDUCES DOWNTIME
- ▶ RETROFITS TO MOST PACKING CASES
- ▶ LONG SERVICE LIFE
- ▶ NO SPECIAL MAINTENANCE REQUIRED

for a Static-Pac seal is less than three years. How quickly an investment in a Static-Pac seal is recovered depends on a number of operating variables. However, regardless of whether a compressor maintains pressure during idle-time or releases pressure by blowdown or other means, a Static-Pac seal will deliver substantial cost savings, improve safety and help ensure environmental compliance.

SAFETY AND ENVIRONMENTAL PROTECTION

Benefits of a Static-Pac seal go beyond financial considerations. Volatile and explosive emissions can accumulate, creating health and safety hazards. Static-Pac seals remove the pressure from ventilation systems, providing an extra layer of safety for the plant and employees.

Environmental protection is another major concern. A study by EPA/GRI* concluded that 21% of all gas emissions within the natural gas industry come from reciprocating

compressors. Static-Pac seals can play a major role in reducing the release of greenhouse and other gases into the environment.

OPERATION AND MAINTENANCE

Once installed, Static-Pac seals become a transparent addition to the piston rod seal assembly, requiring no special maintenance. The service life of a Static-Pac seal under normal operating conditions will typically be several times that of conventional rod rings that seal dynamically.

BANK ON IT

For businesses that rely on reciprocating compressors, leakage is a constant problem. A Static-Pac seal will reduce costs, increase profits, enhance safety and improve environmental compliance. No other solution offers so much, yet costs so little. Call Cook Compression today to find out how a Static-Pac seal can work for you.

*US Environmental Protection Agency/Gas Research Institute

Payback Analysis

Static-Pac seals have demonstrated the ability to eliminate up to 96% of fugitive emissions. Actual results for a given compressor may vary based upon operating conditions and other variables. Contact Cook Compression for a detailed analysis of your operation.

EXAMPLE PAYBACK PERIOD MATRIX

Existing Packing Case Leak Rate (cfm natural gas per rod)	Payback Period (years)	
	Two compressors per engine	Three compressors per engine
0.9	2.3	1.9
1.9 (industry avg.)	0.9	0.8

Based on a study of Static-Pac seals in natural gas pipeline applications performed by the Southern Research Institute. Assumes Static-Pac leak prevention of 96%, industry average downtime of 55% and natural gas price at \$6 per 1,000 cubic feet. Contact Cook Compression for complete details.

SAVINGS (PRESSURIZED STAND-BY)

If compressors are kept in pressurized stand-by, the slow seepage of gas between the rod and packing is a substantial cost. In this case,

determining the savings from a Static-Pac seal is straightforward. First, determine the volume of gas lost per unit of time. If Static-Pac seals eliminate 96% of these losses, the difference between the two rates of loss is the added value.

SAVINGS (DE-PRESSURIZED STAND-BY)

If compressors are de-pressurized during stand-by periods, Static-Pac seals can eliminate the waste of these purge or blow-down operations. While other sources for leakage exist, they typically are manageable. The point of greatest leakage is along the piston rod. Static-Pac seals virtually eliminate this leakage.

Depending on your compressor's leak rate and the amount of stand-by your business requires, savings can be substantial. In general, the more downtime and the more leakage in your current operation, the greater the potential savings with Static-Pac seals.



EnviroMetrix TECHNOLOGY *Today, we know more about the cost of fugitive emissions to the environment. Cook Compression has always known what they can cost to our customer. This is why Cook has led the development and engineering of sealing products for over 100 years. No one knows more about keeping gases and liquids where they belong. Our offerings that carry the EnviroMetrix logo have been specifically engineered to contain fugitive emissions.*



One Name, a World of Solutions

CookCompression.com

- Compressor Valves | Capacity Control | Valve Restraining Systems | Rod Rings | Packing Cases | Piston Rings | Rider Rings
- Pistons | Rods | Cylinder Liners | Compressor and Engine Repair Services | Diagnostics and Analysis Services | Online Monitoring
- and Response Systems | Lubrication Systems and Services | Control and Automation | Engineering and Technical Support