

COOK CLEAN

The Solution to Fugitive Emissions

COOK CLEAN provides comprehensive solutions for reducing compressor packing case emissions to a level that ensures regulatory compliance. Some COOK CLEAN options decrease emissions substantially — even without using purge gas. Others are capable of reducing emissions below measurable limits.



THE CHALLENGE OF EMISSIONS CONTROL

Although leakage can be minimized by properly specifying and maintaining the case, rings and rod, the fundamental design of reciprocating compressors makes gas leakage practically unavoidable. Therefore, some type of barrier method must be employed to prevent emissions from escaping into the atmosphere. COOK CLEAN is the industry leader in purged packing systems.

AL RING — THE KEY TO NITROGEN PURGING

The first nitrogen-purged systems simply introduced nitrogen into the packing case to block the flow of ring leakage beyond the vent. However, these systems could not properly seal the barrier chamber, resulting in excessive nitrogen consumption. Cook Compression solved this limitation by inventing the AL ring. The AL ring establishes an effective barrier in a single groove. Since it seals in either direction, it also eliminates the possibility of being installed backwards.

The AL ring is a five-ring configuration using a center wedge sandwiched by outer wedge rings on both sides. Between the cup faces and the outer wedge rings are butt tangent rings. The center wedge ring is forced inward

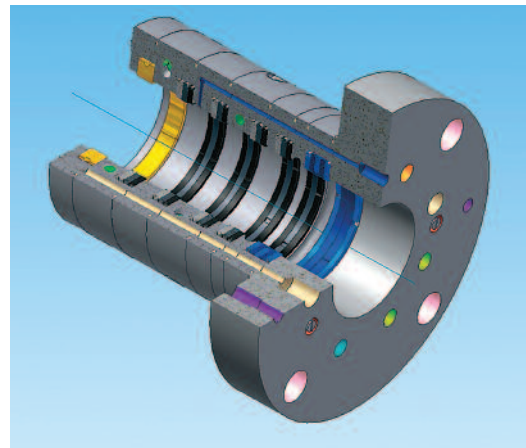

BENEFITS

- ▶ REDUCES FUGITIVE EMISSIONS TO DESIRED LEVELS
- ▶ EASY, ECONOMICAL TO CONVERT MOST COMPRESSORS
- ▶ AL RING CREATES EFFECTIVE SEAL, MINIMIZING PURGE GAS CONSUMPTION
- ▶ OPTIONAL MONITORING SYSTEM ALLOWS PREDICTIVE MAINTENANCE
- ▶ STATIC-PAC SEALS DURING SHUTDOWN

Enhanced Design

Recent design enhancements extend the run time of the packing set and provide extra protection to prevent debris from entering the gas vent.

Primary features include:

- The addition of an RYL ring, which scrapes debris and liquids from the rod before they reach the AL ring.
- Dual Vent/Drain system that includes an enlarged drain to collect oil and debris scraped from the rod, plus a separate, secondary gas vent.

COOK CLEAN —
a range of options to achieve any emissions-reduction objective

toward the rod, which in turn forces the outer rings against the cup faces to create a seal. In effect, sealing is maintained in three places: (1) along the piston rod, (2) at the sides of the cup, and (3) between the rings. All seals are maintained by the pressure of the barrier gas and by spring loading.

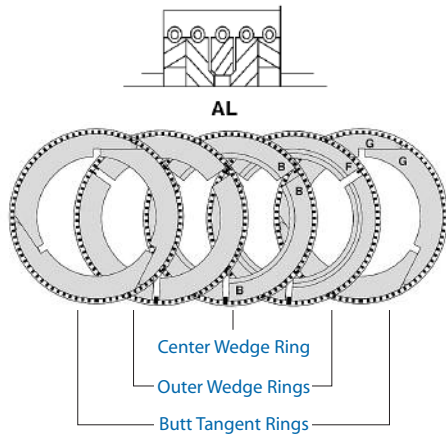

A FEATURE-PACKED CASE

1. A spiral-wound end cup gasket made of a composite stainless steel/nonmetallic material is highly conformable, creating a better seal between the packing case and the compressor
2. O-rings between cups (optional) can be utilized to provide an additional layer of protection from gas leaking between cup faces
3. A raised flange face and separate plate, both of which can be lapped, ensure a tight seal at the AL ring
4. Rings of TFE and other proprietary high-performance plastics not only provide an exceptional seal with

good lubricity, but also resist nearly all chemicals

PREDICTIVE VS. REACTIVE MAINTENANCE

A COOK CLEAN emission-control system not only stops fugitive emissions — it also enables true predictive maintenance. The purging system (which can be automated) provides a means to monitor gas flows and pressures, thereby indicating when packing ring wear is approaching unacceptable limits. For example, with new packing, leakage through the packing rings will be very low. Subsequently, vent pressure will be very low as well. Increasing vent pressure indicates that the packing rings are experiencing wear and leaking at a higher rate than normal.

Another means of monitoring the condition of the packing installation is through the AL ring. Nitrogen is typically applied to the AL ring and will operate at a very low flow rate. Monitoring the system for an increase in flows and pressures can provide advance notice that the installation will soon require service. The predictive nature of this advanced system helps eliminate unscheduled downtime and improves operational reliability.

OPTIONAL CAPABILITIES

SEAL ASSIST SYSTEM (SAS)

SAS is a secondary containment technology that uses a high-velocity

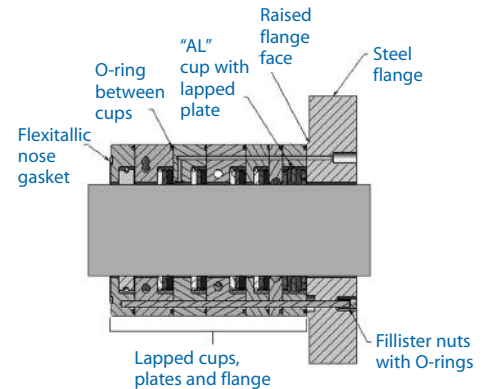

jet stream to capture primary-seal emissions and deliver them to a control point, such as vapor recovery or disposal. SAS reduces packing case emissions to virtually zero ppm.

STATIC-PAC SHUTDOWN SEAL KIT

Static-Pac seals provide close to 100% leakage control when compressors are not operating.

BUFFER/PURGE CONTROL AND GAS MONITORING

An Autocator® control mechanism automates the barrier gas system and allows full benefit of the COOK CLEAN predictive maintenance capability.

EnviroMetrix TECHNOLOGY Today, we know more about the cost of fugitive emissions to the environment. Cook Compression has always known what they can cost to our customer. This is why Cook has led the development and engineering of sealing products for over 100 years. No one knows more about keeping gases and liquids where they belong. Our offerings that carry the EnviroMetrix logo have been specifically engineered to contain fugitive emissions.



One Name, a World of Solutions

CookCompression.com

Compressor Valves | Capacity Control | Valve Restraining Systems | Rod Rings | Packing Cases | Piston Rings | Rider Rings
Pistons | Rods | Cylinder Liners | Compressor and Engine Repair Services | Diagnostics and Analysis Services | Online Monitoring
and Response Systems | Lubrication Systems and Services | Control and Automation | Engineering and Technical Support