

COOK CLEAN SYSTEMS

Solutions for Fugitive Emissions

COOK CLEAN Systems provide comprehensive solutions for reducing compressor packing case emissions. Some COOK CLEAN options decrease emissions substantially — even without using purge gas. Others are capable of reducing emissions below measurable limits.



THE CHALLENGE OF EMISSIONS CONTROL

Although leakage can be minimized by properly specifying and maintaining the case, rings and rod, the fundamental design of reciprocating compressors makes gas leakage practically unavoidable. Therefore, some type of barrier method must be employed to prevent emissions from escaping into the atmosphere. COOK CLEAN – with its high performance and flexible range of design options – is the industry leader in purged packing systems.

A FEATURE-PACKED CASE

A COOK CLEAN packing case includes a variety of innovations, plus optional features to help you meet your specific emissions objectives.

- A spiral-wound end cup gasket made of a composite stainless steel/non-metallic material is highly conformable, creating a superior seal between the packing case and the compressor.
- O-rings between cups (optional) can be used to provide an additional layer of protection from gas leaking between cup faces. If O-rings are not utilized, fillister nuts with O-rings are used to prevent leakage down the tie-rod holes.
- Lapped sealing surfaces for all rod rings.
- Purge/buffer seal using LF Purge Pac® assembly.

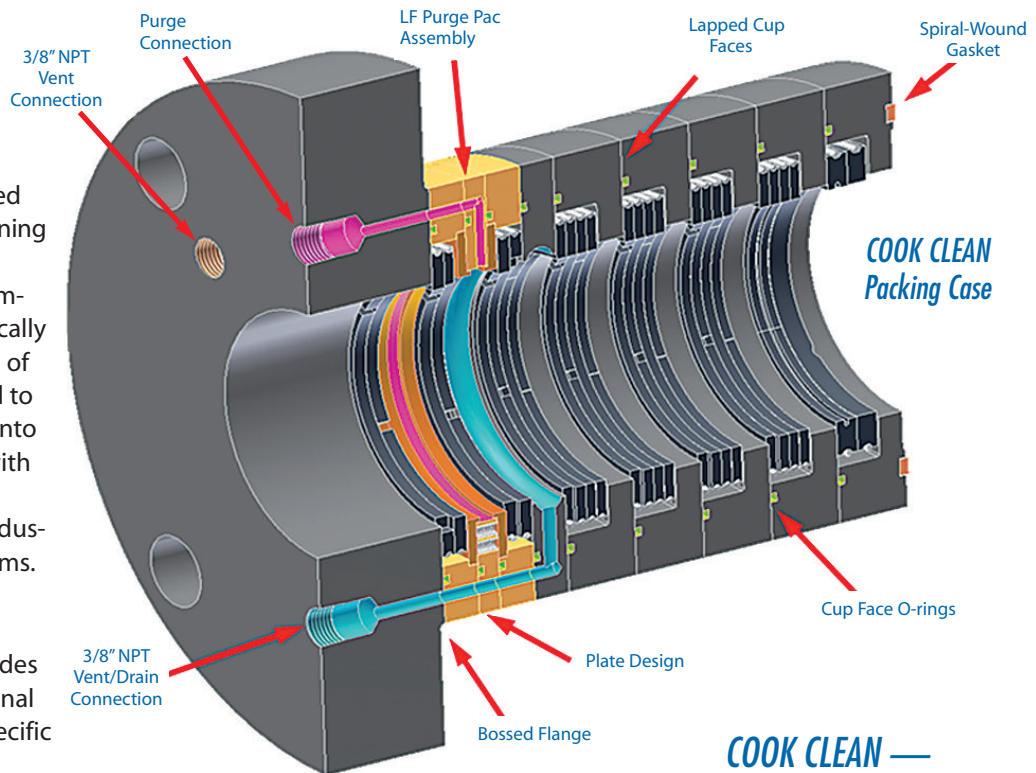

LF PURGE PAC® ASSEMBLY – THE NEXT GENERATION OF PURGE/BUFFER SYSTEMS

One of the key features in a Cook Clean packing case is the purge/buffer system. The purge or buffer in a packing case creates a gas barrier that forces any seal ring leakage into the vent instead of allowing it to continue down the rod into the distance piece.

For years, the industry standard for purge/buffer seals was the Cook Compression 'AL' ring. This side-loading ring establishes an effective barrier seal along the rod, at the sides of the cup

COOK CLEAN — a range of options to achieve any emissions-reduction objective

BENEFITS

- ▶ REDUCES FUGITIVE EMISSIONS TO DESIRED LEVELS
- ▶ EASY, ECONOMICAL TO CONVERT MOST COMPRESSORS
- ▶ LF PURGE PAC ASSEMBLY CREATES EFFECTIVE SEAL, MINIMIZING PURGE GAS CONSUMPTION
- ▶ OPTIONAL MONITORING SYSTEM ALLOWS PREDICTIVE MAINTENANCE
- ▶ STATIC-PAC SEALS DURING SHUTDOWN

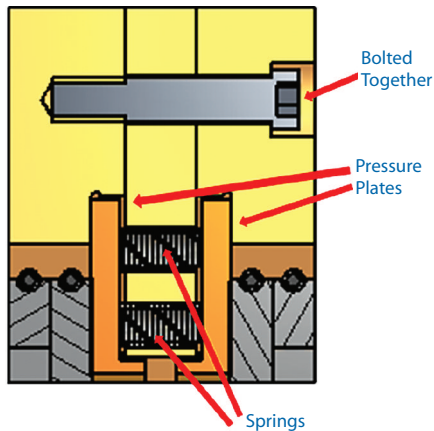

LF Purge Pac Assembly

and between the rings themselves in a single groove. However, the center wedge ring of the 'AL' design creates additional heat, which can reduce ring life. Continuing research led to a longer-lasting solution: the LF (Low-Friction) Purge Pac assembly.

The LF Purge Pac assembly offers the same barrier-sealing, side-loading performance of an 'AL' ring - without the additional heat generated by the center wedge ring. This is accomplished by using axial springs and pressure plates to side-load standard 'BT' seal rings. Plates and springs are preassembled and bolted into the LF Purge Pac assembly at the factory to create ring grooves where 'BT' rings will fit. The LF Purge Pac assembly is self-contained, simplifying installation and maintenance by eliminating small, loose parts. These rings can

be replaced along with the rest of the packing without taking apart the assembly.

ENHANCED DESIGN

Recent design enhancements extend the run time of the packing set and provide extra protection to prevent debris from entering the gas vent. Primary features include a dual vent/drain system that incorporates an enlarged drain to collect oil and debris scraped from the rod, plus a separate, secondary gas vent.

OPTIONAL CAPABILITIES

SOLID RING TECHNOLOGY™

Cook Solid Ring Technology increases the sealing efficiency of packing rings by using the elastic modulus of specifically selected rod ring materials to create a superior seal while reducing frictional heat. Backup rings also act as seal rings, which increases overall sealing effectiveness and reduces the rod temperature by dispersing the frictional load.

STATIC-PAC SHUTDOWN SEAL KIT

Static-Pac seals provide close to 100% leakage control when compressors are not operating.

PURGE/BUFFER CONTROL AND GAS MONITORING

An Autocator® control mechanism automates the barrier gas system and allows full benefit of the COOK CLEAN predictive maintenance capability.

SIDE-LOADED WIPER

A special side-loaded wiper ring scrapes debris and liquids from the rod before they reach the LF Purge Pac seal.

PREDICTIVE MAINTENANCE

A COOK CLEAN emission-control system not only reduces fugitive emissions — it also enables true predictive maintenance. The purging system (which can be automated) provides a means to monitor gas flows and pressures, thereby indicating when purge ring wear is approaching unacceptable limits.

Nitrogen is typically applied to the purge cavity and will operate at a very low flow rate. Monitoring the system for a change in flows and pressures can provide advance notice that the installation will soon require service. The predictive nature of this system helps eliminate unscheduled downtime and improves operational reliability.

 *Cook Compression products and services that carry the EnviroMetrix logo are specifically engineered to contain fugitive emissions — reducing operating costs for our customers and helping protect our environment.*



One Name, a World of Solutions

CookCompression.com

Compressor Valves | Capacity Control | Valve Restraining Systems | Rod Rings | Packing Cases | Piston Rings | Rider Rings
Pistons | Rods | Cylinder Liners | Compressor and Engine Repair Services | Diagnostics and Analysis Services | Online Monitoring
and Response Systems | Lubrication Systems and Services | Control and Automation | Engineering and Technical Support